

PARAMETRIC STUDY ON INFLUENCE OF SURCHARGE LOADING, RETAINED SOIL AND RESTRAINED SOIL ON DESIGN OF DIAPHRAGM WALL (WITHOUT SURCHARGE LOAD CASE)

Nu Nu Win¹, Nyan Myint Kyaw²,

¹PhD Candidate Student, ²Professor,

^{1,2}Faculty of Civil Engineering, Yangon Technological University, Myanmar

Email - ¹dawnunuwin.civil@gmail.com, ²nmkyaw@gmail.com

Abstract: In Yangon, Myanmar is encountered deep excavation problem. Many buildings can be damaged due to the excavation of adjacent building. Therefore, embedded retaining wall as excavation support system is necessary to be sustainable buildings. The project site is located in North Dagon Township in Yangon Myanmar. Subsoil condition is soft, medium (low) clay for retained soils, medium (low), stiff, medium, hard clay soil layer existed as restrained soil. Surcharge load is very important in the embedded wall. In this paper, without surcharge, load are considered. Soil design parameters are obtained from SPT with relative cohesion C and soil stiffness. $\phi = 0$, the undrained condition is considered on the design of diaphragm wall with three boundary conditions such as Upper Bound (Avg: $C_u = 105.27 \text{ kN/m}^2$), Middle Bound (Avg: $C_u = 71.77 \text{ kN/m}^2$), Lower Bound (Avg: $C_u = 32.38 \text{ kN/m}^2$). Lower Bound is not suitable for freestanding cantilever wall. In this paper, depth ratio Vs SUM Msf, over ground loss distance, prediction ground movements are described. Depth ratio means the ratio of excavation depth to wall depth. Moreover, results of soil structure interaction analysis (PLAXIS) such as ground movements and wall deflections are compared with to Aye 2014, Bowles (fifth edition), and modified Aye 2017 for $C = 0$ soil condition. This paper ensures support to be a sustainable building.

Key Words: diaphragm wall, cohesion soil, overground loss distance, wall depth, Depth ratio, ground movement.

1. INTRODUCTION:

Embedded retaining wall as excavation support system is necessary to be sustainable buildings [1]. There are important that influence of surcharge loading, retained soil and restrained soil on the design of embedded retaining wall. In this paper, diaphragm Wall is emphasized and solved using soil-structure interaction analysis. Diaphragm retaining walls can be constructed to form deep basements or retaining structures.

1.1 Objective of the this paper is

- To apply unit less ratio on the design of diaphragm wall for future application, and
- To analyze behavior of design of diaphragm wall.

1.2. Scope of the this paper is

- surcharge load case - 13 to 11.5 kN/m^2 ,
- no surcharge load case,
- $\phi = 0$, condition,
- 5 m depth cantilever retaining wall,
- Excavated width is 30m,
- Level ground surface retained soils,
- using soil-structure interaction analysis (Plaxis), and
- Diaphragm wall properties are $EA = 7.5 \times 10^6 \text{ kN/m}$. $EI = 1.0 \times 10^6 \text{ kN/m}^2/\text{m}$ and equivalent thickness $d = 1.265 \text{ m}$.

1.3. Methodology-

- Establishing of limit states
- Reviewing ground and groundwater conditions
- Selection of wall type
- Finding of loads
- Determination of wall depth for overall lateral stability using ultimate limit state

- Prediction of wall deflections and ground surface movements using serviceability limit states.

1.4. Outline of the paper

This paper is composed of five chapters.

1. Establishing of limit states,
2. Reviewing ground and groundwater conditions,
3. Selection construction sequence and wall type,
4. Finding of loads,
5. Determination of wall depth for overall lateral stability using ultimate limit state, and
6. Prediction of wall deflections and ground surface movements using serviceability limit states.

2. LITERATURE REVIEW:

2.1 Introduction

Design calculations should satisfy the ultimate limit states (ULS) of wall stability and structural strength and the required serviceability limit states (SLS) by verifying satisfactory wall performance in respect of wall deflections, associated ground movement, wall water tightness Criteria. The factor F_s should be applied to soil strength [1].

In general, the designer should undertake the following sequential steps:

1. Establishing of limit states,
2. Reviewing ground and groundwater conditions,
3. Selection of wall type,
4. Finding of loads,
5. Selection of Soil Design Parameters,
6. Determination of wall depth for overall lateral stability using ultimate limit state, and
7. Prediction of wall deflections and ground surface movements using serviceability limit states.

Uncertainty in the selection of soil strength, stiffness, load and geometric parameters are of particular importance in retaining wall design. The literature contains many correlations between the standard penetration number and the undrained shear strength of clay C_u . On the basis of results of undrained triaxial tests conducted on insensitive clays. Stroud (1974) suggested that:

$$C_u = K N_{60} \quad \text{Equation 2.1}$$

where

K = constant = 3.5-6.5 kN/m² (0.507-0.942 lb/in²)

N_{60} = standard penetration number obtained from the field

The average value of K is about 4.4 kN/m² (0.638 lb/in²)

In the determination of Wall Depth for Overall Lateral Stability Using Ultimate Limit State, soil structure interaction analysis (Plaxis) is used for wall depth with overall lateral stability. $F_s=1.4$ for C and $F_s=1.25$ for ϕ . $E_{ULS}=1/2E_{SLS}$.

Plaxis is the finite element package that has been developed specifically for the analysis of deformation and stability in geotechnical engineering projects.

The elastic-plastic Mohr-Coulomb model involves five input parameters, ie E (Young's modulus kN/m²) and ν (Poisson's ratio) for soil elasticity; ϕ (friction angle °) and C (cohesion kN/m²) for soil plasticity and ψ (dilatancy angle°) as an angle of dilatancy. Besides the five model parameters, initial soil conditions play an essential role in most soil deformation problems. Initial horizontal soil stresses have to be generated by selecting proper k_0 values [14].

In Prediction of Wall Deflections and Ground Surface Movements Using the Serviceability Limit States, soil structure interaction analysis(Plaxis) is used for wall depth with overall lateral stability. $F_s=1$ for C and f . $E_{SLS} = 2 E_{ULS}$.

2.2 Prediction for Horizontal Movements

I. Aye 2014 method

This method is based on Zaw Zaw Aye. 2014. Current practices in Deep Foundations and Diaphragm Wall Construction in Thailand. The title is Ground Movement Prediction and Building Damage Risk –Assessment for the Deep Excavations and Tunnelling Works in Bangkok Subsoil.

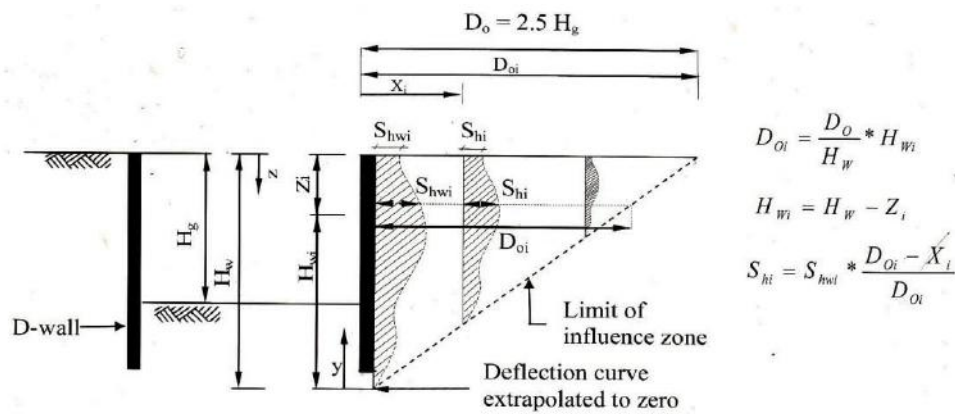

Figure 2.1 Demonstration of Subsurface Horizontal Movement Prediction from Diaphragm Wall Deflection Values

$D_0 = D_{oi}$ = over ground loss distance from the wall
 $D_0 = 2.5 H_g$
 H_g = Excavation Depth (m)
 S_{hi} = horizontal ground movement
 S_{hwi} = horizontal ground movement at the wall
 X_i = Distance from wall to surcharge

$$S_{hi} = S_{hwi} * \frac{D_{oi} - X_i}{D_{oi}} \quad \text{Equation 2.2}$$

II. Modified Aye 2017 method

$$D_0 = C_1 H_w \quad \text{Equation 2.3}$$

$$S_{hi} = S_{hwi} * \frac{D_{oi} - X_i}{D_{oi}}$$

$D_0 = D_{oi}$ = over ground loss distance (m)
 H_w = wall depth (m)
 S_{hi} = horizontal ground movement
 S_{hwi} = horizontal ground movement at the wall
 C_1 = constant factor

III. Prediction from soil structure interaction analysis these results are obtained by PLAXIS

2.3 Prediction for Vertical Ground Movements

Prediction for vertical ground movement by soil structure interaction analysis (PLAXIS), firstly PLAXIS results ($x=0$ m, $x=2$ m, $x=4$ m) are obtained. Then vertical deflections are determined based on Bowles method, Aye 2014 method, Modified Aye 2017 method, Modified Bowles method.

I. Bowles Method (Estimation of Ground Loss Around Excavations)

1. Obtain the estimated lateral wall deflection profile.
2. Numerically integrate the wall deflections to obtain the volume of soil in the displacement zone V_s . Use average end areas, the trapezoidal formula, or Simpson's one-third rule.
3. Compute or estimate the lateral distance of the settlement influence. The method proposed by Caspe for the case of the base soil being clay is as follows:
 - a. Compute wall height to dredge line as H_w
 - b. Compute a distance below the dredge line H_p $H_t = H_w + H_p$, B = width of excavation

Soil Type	Use $H_p \cong$ dredged level to end of the wall
$\phi = 0$	B
$\phi - C$	$0.5 B \tan (45 + \phi / 2)$

- c. Compute the approximate distance D from the excavation over which ground loss occurs as

$$D = H_t \tan(45^\circ - \phi/2), \quad \text{Equation 2.4}$$

4. Compute the surface settlement at the edge of the excavation wall as

$$S_w = 2V_s / D,$$

D = over ground loss distance, S_w = movement at the wall

5. Compute remaining ground loss settlements assuming a parabolic variation of s, from D toward the wall as

$$S_i = S_w (x/D)^2, \quad S_i = \text{movement at } x \text{ distance from wall [15]}$$

II. Aye 2014 method

This method is based on Zaw Zaw Aye. 2014. Current practices in Deep Foundations and Diaphragm Wall Construction in Thailand. The title is Ground Movement Prediction and Building Damage Risk – Assessment for the Deep Excavations and Tunneling Works in Bangkok Subsoil.

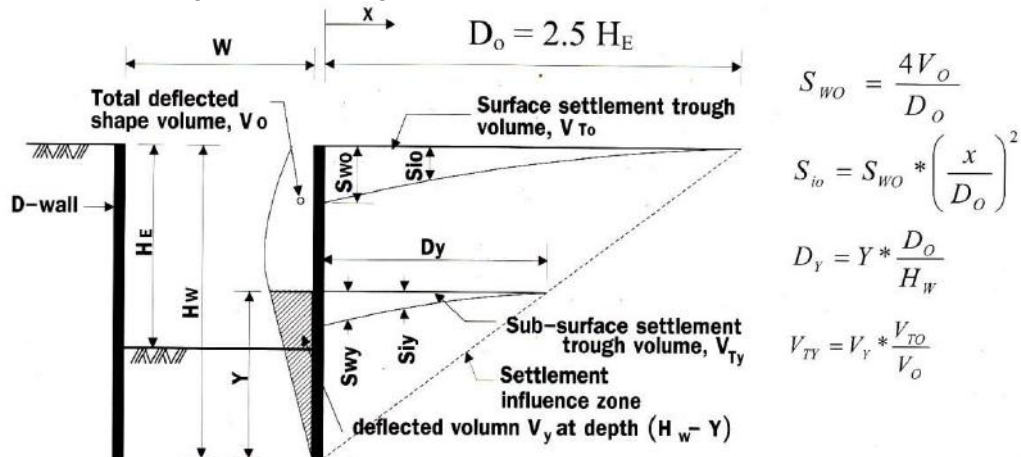

Figure 2.4. Demonstration of Subsurface Settlement Prediction from Diaphragm Wall Deflection Values

The equation for the verticle movement along the distance x from the Diaphragm wall should be:

$$S_{io} = S_{w0} * \left[\frac{D_o - x}{D_o}\right]^2 \quad \text{Equation 2.4}$$

And $S_{w0} = V_o / D_o$.

S_{w0} = surface settlement at the wall

V_o = total deflected shape volume

$D_o = D_{oi}$ = over ground loss distance (m)

$D_o = 2.5 * H_E$

H_E = Excavation depth (m)

S_{io} = surface settlement

X = Distance of wall to surcharge (m)

III. Modified Aye 2017 method

$$S_{w0} = V_o / D_o$$

S_{w0} = surface settlement at the wall

$$D_o = C_2 H_w \quad \text{Equation 2.5}$$

H_w = wall depth (m)

$$S_{io} = S_{w0} * \left[\frac{D_o - x}{D_o}\right]^2 \quad \text{Equation 2.6}$$

IV. Modified Bowles method

$S_w = 2V_s / D$, D = over ground loss distance, S_w = movement at the wall

$S_i = S_w (x/D)^2$, S_i = movement at x distance from the wall

$$D = C_3 H_w \quad \text{Equation 2.7}$$

H_w = wall depth (m)

3. RESULTS AND DISCUSSION:

This portion involves site location, soil stratification, soil design parameters, Determination of wall depth and ground movement using PLAXIS, comparison of the methods such as Aye 2014, Modified Aye 2017, Bowles (fifth edition).

3.1 Site Location

The project site is located Bo Ba Htoo Street, North Dagon Township in Yangon Myanmar. Figure 3.1 and 3.2 represent site location and borehole location.

All Boreholes have soft subsoil condition up to 3 m depth below the existing grade. But in Borehole 3, up to 13.5 m is soft soil layer. Maximum depths of boreholes are 41 m, 39.20m, 40.7m, 44 m respectively.

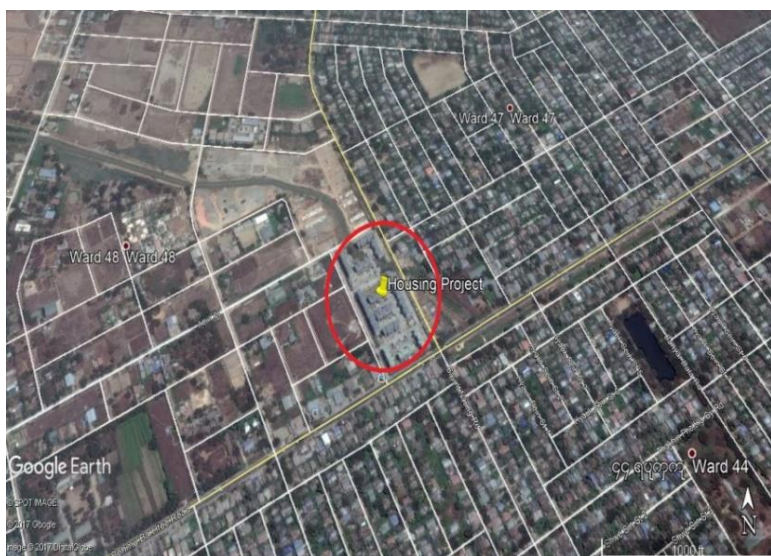

Figure 3.1. Site Location

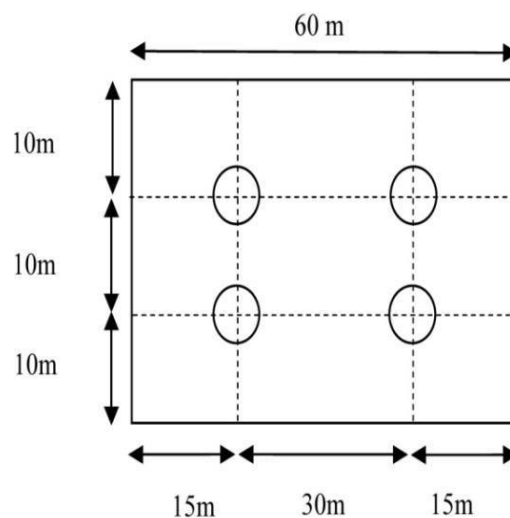

Figure 3.2. Bore Hole Location

3.2 Soil Stratification

In borehole 1, medium/stiff/hard soil layers are encountered below the soft soil condition up to 34.5 m. Then very stiff soil with the thickness of 4.5 m existed and it is followed by hard soil up to end of the borehole. In borehole 2, medium/dense/very stiff/ hard soil layers existed below the soft soil condition up to end of the borehole.

In borehole 3, after 13.5 m thickness of soft soil layer, medium soil layer existed up to 25.5m, but between 19.5 m to 21 m is hard soil layer. The borehole has medium/very stiff/ hard/ dense condition of soil layer from 25.5 m to end of the borehole.

In borehole 4 has 3 m thickness soft soil layer. It is followed by stiff/very stiff/ hard soil layer up to end of the borehole. Based on the field investigation and laboratory analysis of representative soil samples and stratigraphy in the sub-surface up to end of the borehole depth, engineering properties of relevant soil layers have been determined.

3.3 Soil Design Parameters for Three Boundary Conditions

Figure 3.3 describes the determination of three boundary condition of SPT with Soil Layers. Figure 3.4 shows C_u vs. Depth. From the Figure, Average Upper Bound C_u is 105.27 kN/m^2 , Average Middle Bound of C_u is 71.77 kN/m^2 and Average Lower Bound of C_u is 32.38 kN/m^2 .

3.4 Material Properties for input parameter of PLAXIS

In this case, three boundary conditions are considered with various depths using PLAXIS. Summaries of Ground Parameters are described in Table 3.1 and an example of the input parameter for Material properties of the soil layers is showed in Table 3.2 and Material properties of Diaphragm wall (plate) is described in Table 3.3. Without surcharge load and with surcharge load cases are considered with same material properties.

3.5 Determination of Wall Depth for Overall Lateral Stability with Ultimate Limit State, Without Surcharge Load

Figure 3.5 is the failure of Lower Bound case. Figure 3.6 shows Depth Ratio Vs SUM Msf for Without Surcharge Load. Depth ratio means the ratio of wall depth to excavation depth. In Upper Bound Case, Depth ratio is increased 3 to 6; SUM Msf is increased as 2.64 to 3.88. Depth ratio 2 is not suitable because the control panel additional step is 70. In Middle Bound Case, Depth ratio 3 and 4 is not suitable because SUM Msf is less than 1.5. Depth ratios 5.2 and 6 have SUM Msf 1.54 and 1.7.

3.6 Prediction of Wall Deflections and Ground Surface Movements using Serviceability Limit States, Without Surcharge Load

3.6.1 Horizontal Displacement (Upper Bound Case)

Horizontal displacement From the PLAXIS is determined at DR= 6,5,2, 4, 3. In Figure 3.7 represents horizontal displacements with depth ratio = 6.

Vertical distances from the top of the wall corresponding with horizontal displacements at x= 0 m, x= 2m, x= 4m are described. x = horizontal distances from the wall. Vertical distances from the top of the wall are 0 m, 2 m, 4 m, 5m respectively.

At the surface, horizontal displacements at x= 0 m is 7.18 mm, horizontal displacements at x= 2 m is 6.59 mm and horizontal displacements at x= 4 m is 5.99 mm respectively.

At the verticle distances from the top of the wall 5m, horizontal displacement at x= 0 m is 6.88 mm, horizontal displacement at x= 2 m is 6.72 mm and horizontal displacement at x= 4 m is 6.14 mm respectively.

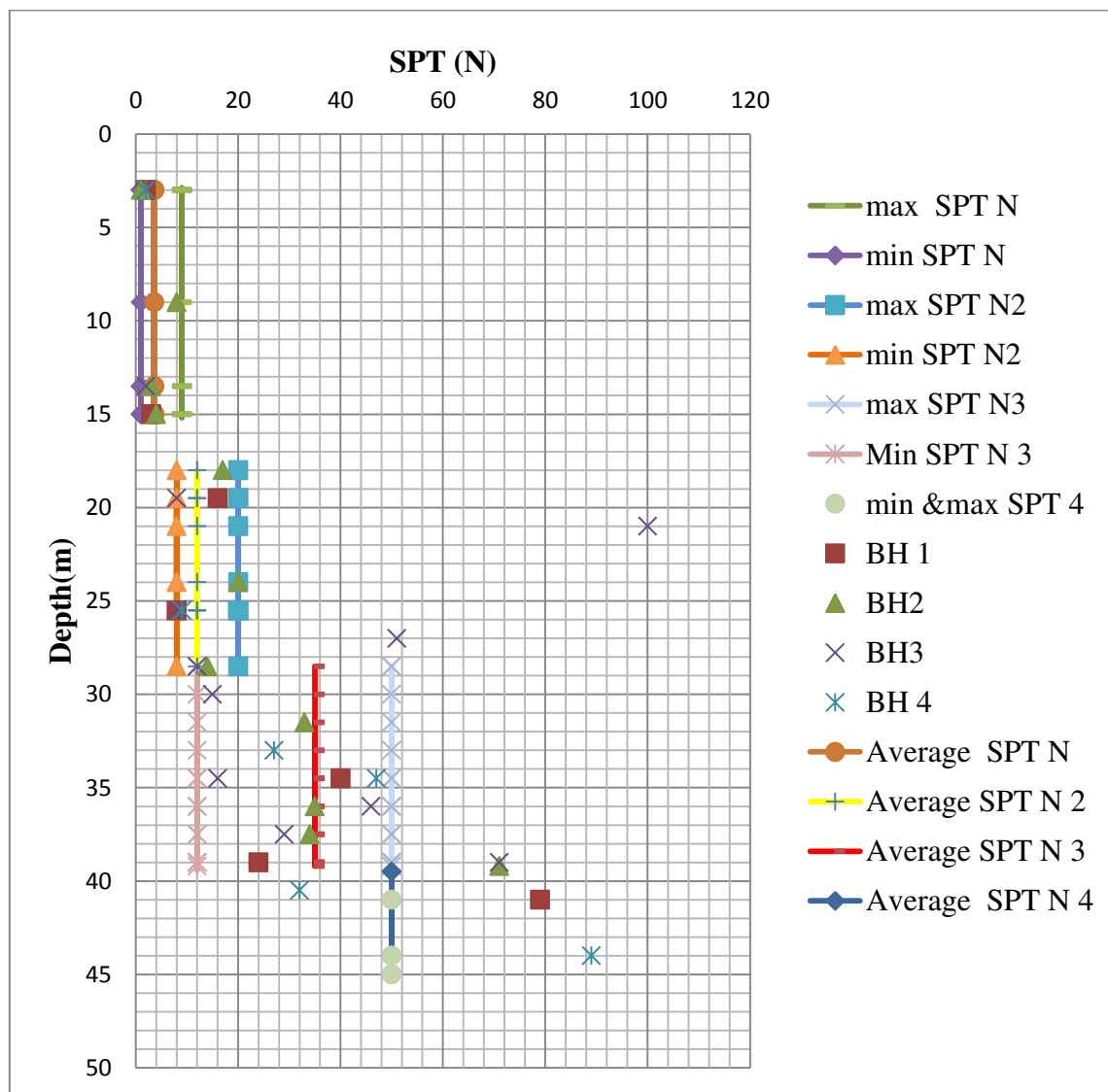

Figure 3.3. Determination of Three Boundary Condition of SPT with Soil Layers

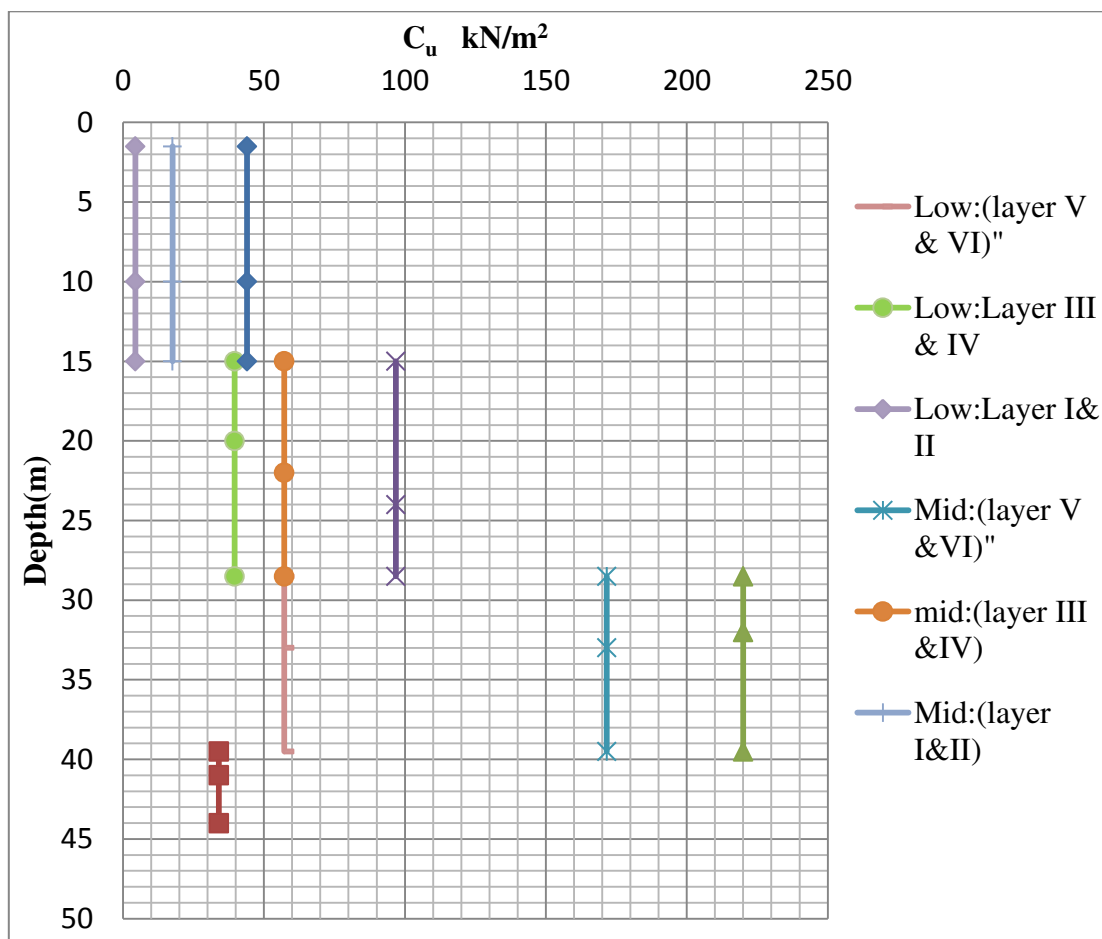

Figure 3.3. Three Boundary Condition of Design C_u

Table 3.1. Summaries of Ground Parameters

Name	I	II	III	IV	V	VI	VII	Unit
Type	CL	CH	CL	CH,CL	CH	CL,CH	SM	
Layers	1.5-3.0	3.0-15.0	15.0-20	20-26.0	26.0-35.0	36.0-39.0	39.0-41.0	(m)
γ_{dry}	16	12	17	14	16.5	16.25	15	kN/m^3
γ_{sat}	19	18	20.4	19	19.5	20.0	19	kN/m^3
E_{SLSU}	44000	44000	96800	96800	220000	220000	79000	kN/m^2
E_{SLSM}	17600	17600	57200	57200	171600	171600	79000	kN/m^2
E_{SLSL}	4400	4400	39600	39600	57200	57200	79000	kN/m^2
ν	0.35	0.35	0.35	0.35	0.35	0.35	0.3	-
$C_u U$	44	44	96.8	96.8	220	220	34	kN/m^2
$C_u M$	17.6	17.6	57.2	57.2	171.6	171.6	34	kN/m^2
$C_u L$	4.4	4.4	39.6	39.6	57.2	57.2	34	kN/m^2

Table 3.2. Material Properties of the Soil Layers and the Interfaces for Upper Bound

Particular		L I,II	L III,IV	LV,VI	L VII	Unit
Material	Model	MC	MC	MC	MC	
Type of material behavior	Type	Undrained	Undrained	Undrained	Undrained	
Dry soil unit weight	γ_{dry}	16 ,12	17,14	16.5,16.25	15	kN/m ³
Saturated soil unit weight	γ_{sat}	19,18	20.4,19	19.5,20.0	19	kN/m ³
Permeability in hor: direction	K_x	0.001	0.001	0.001	1.0	m/day
Permeability in ver: direction	K_y	0.001	0.001	0.001	1.0	m/day
Young's modulus	E_{sls}	44000	96800	220000	79000	kN/m ²
Poisson's ratio	ν	0.35	0.35	0.35	0.3	
Cohesion	C_u	44	96.8	220	34	kN/m ²
Friction angle	ϕ	0	0	0	0	
Dilatancy angle	ψ	0.0	0.0	0.0	2.0	
Strength reduction factor inter	R_{inter}	0.5	0.5	0.5	0.67	

Table 3.3. Material Properties of the Diaphragm Wall (Plate)

Parameter	Name	Value	Unit
Type of behavior	Material type	Elastic	
Normal stiffness	EA	$7.5 \cdot 10^6$	kN/m
Flexural rigidity	EI	$1.0 \cdot 10^6$	kN/m ² /m
Equivalent thickness	d	1.265	m
Weight	w	10.0	kN/m/m
Poisson's ratio	ν	0.0	-

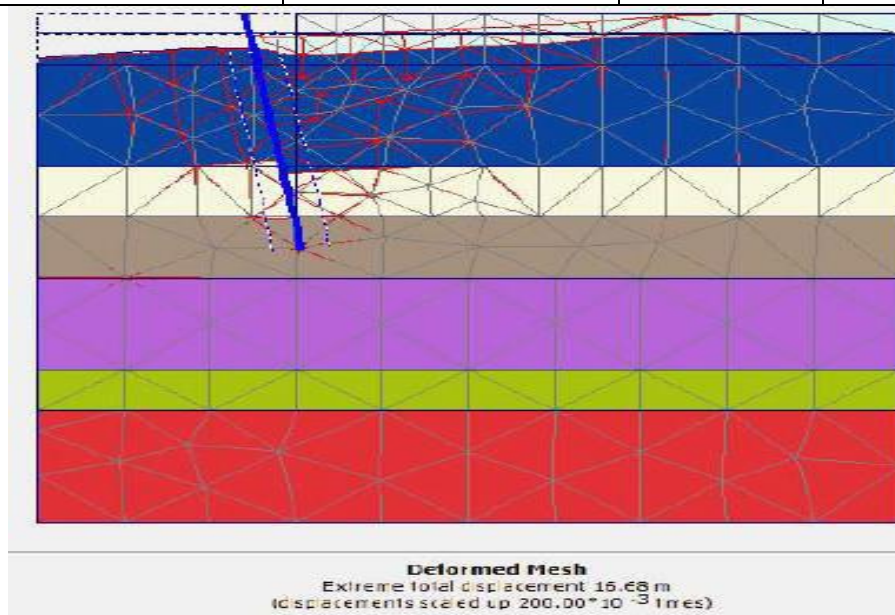

Figure 3.5. Failure of Lower Bound Case

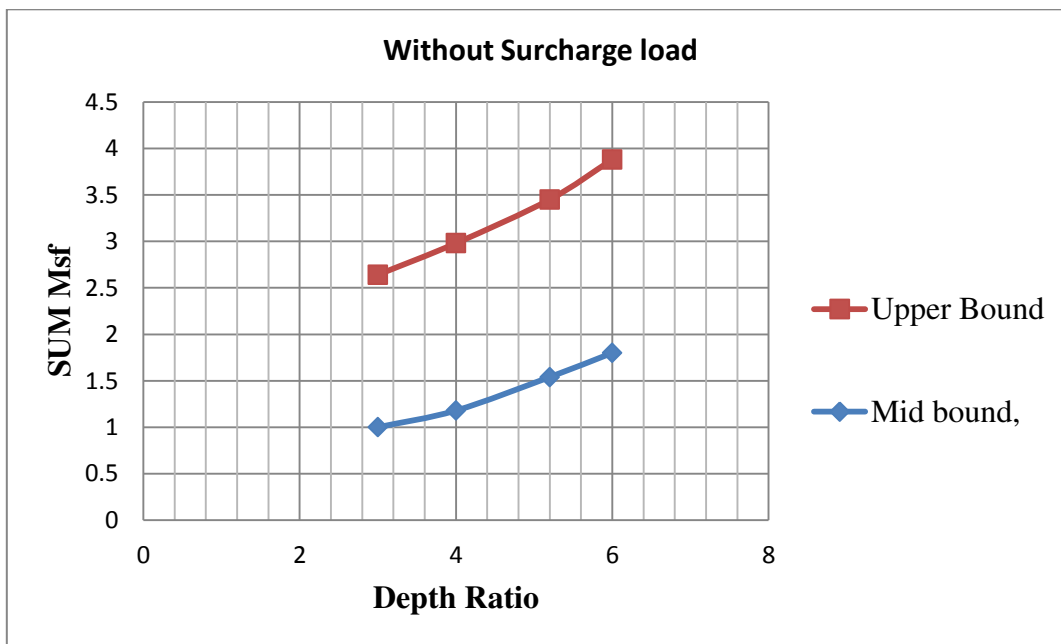

Figure 3.6. Depth Ratio Vs SUM Msf for Without Surcharge Load

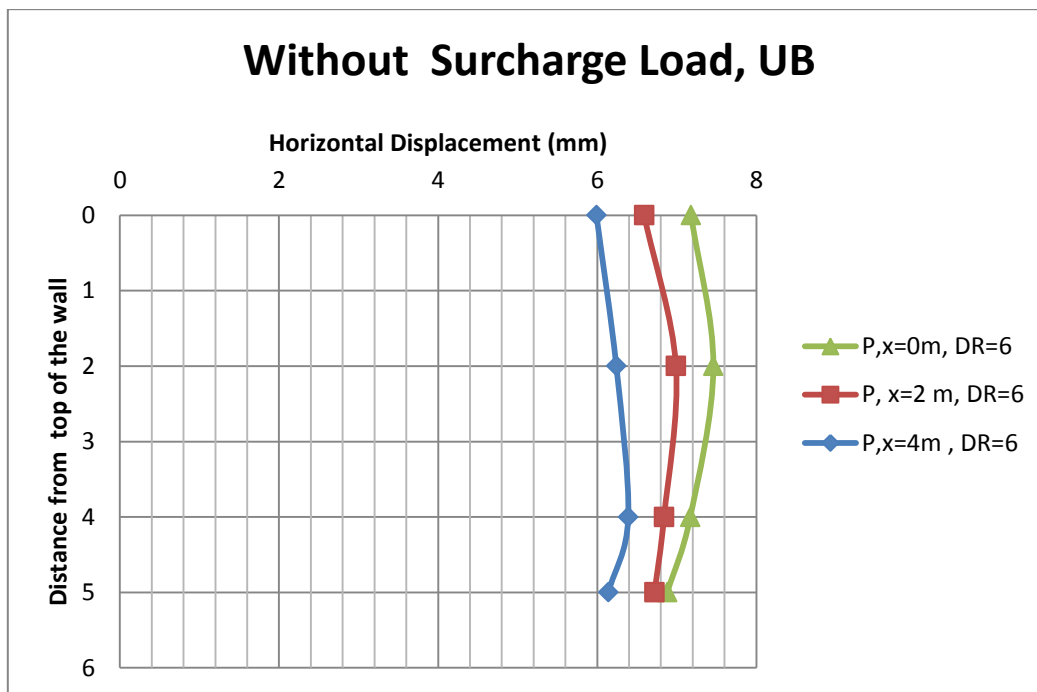

Figure 3.7. Horizontal Displacements with Distances from Top of the Wall, DR=6

3.6.2 Horizontal Displacement (Middle Bound Case)

Horizontal displacement From the PLAXIS are determined at DR= 6,5.2 , 4, 3. In Figure 3.8 represents horizontal displacements with depth ratio = 6. At the surface, horizontal displacements at x= 0 m is 23.3 mm, horizontal displacements at x= 2 m is 20.22 mm and horizontal displacements at x=4 m is 18.02mm respectively. At the vertical distances from the top of the wall 5m, horizontal displacement at x= 0 m is 19.66 mm, horizontal displacement at x= 2 m is 18.49 mm and horizontal displacement at x= 4 m is 16.79 mm respectively.

3.6.3 Comparison for Prediction of Horizontal Movements

I. Upper bound case

Figure 3.9 and 3.10 are represented horizontal displacement by aye 2014 method and modified aye 2017 method. The ratio of PLAXIS to Aye 2014 and Modified Aye 2017 are described together in Figure 3.11. Overground loss distance from the wall (Do) is $\frac{3}{4}$ Hw for Depth Ratio 6. Ratio of Plaxis to Aye 2014 (x = 0 to x= 4 m) DR = 6 is 1 to 1.227 at top of the wall, 1 to 1.45 at depth = 5 m. Ratio of Plaxis to Modified Aye 2017 (x=0 to x= 4 m) DR = 6 is 1 to 1.04 at top of the wall, 1 to 1.134 at depth = 5 m.

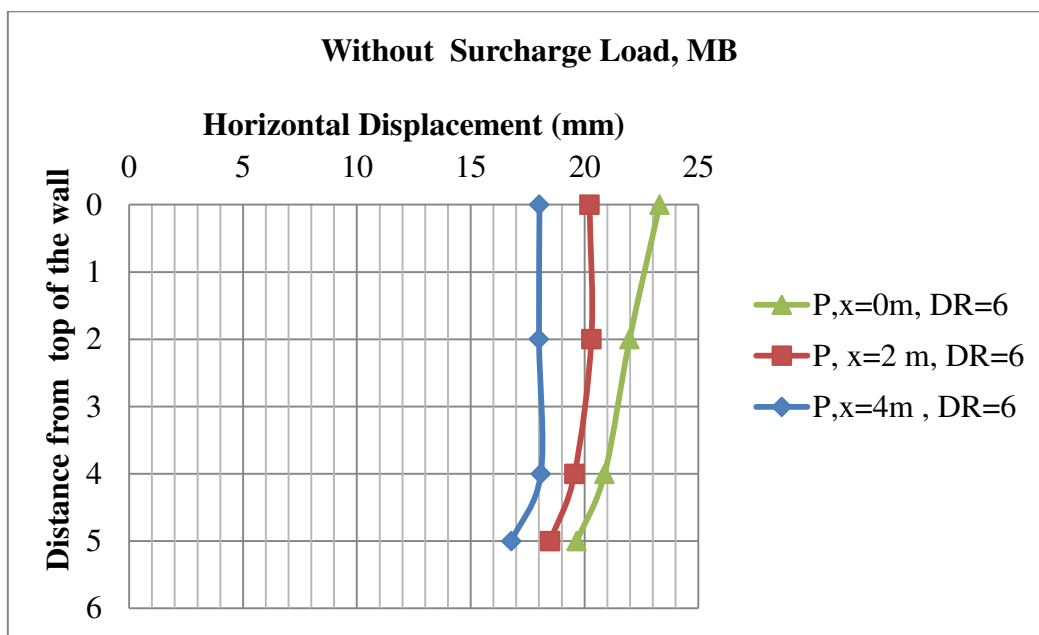

Figure 3.8. Horizontal Displacements with Distances from Top of the Wall, DR=6

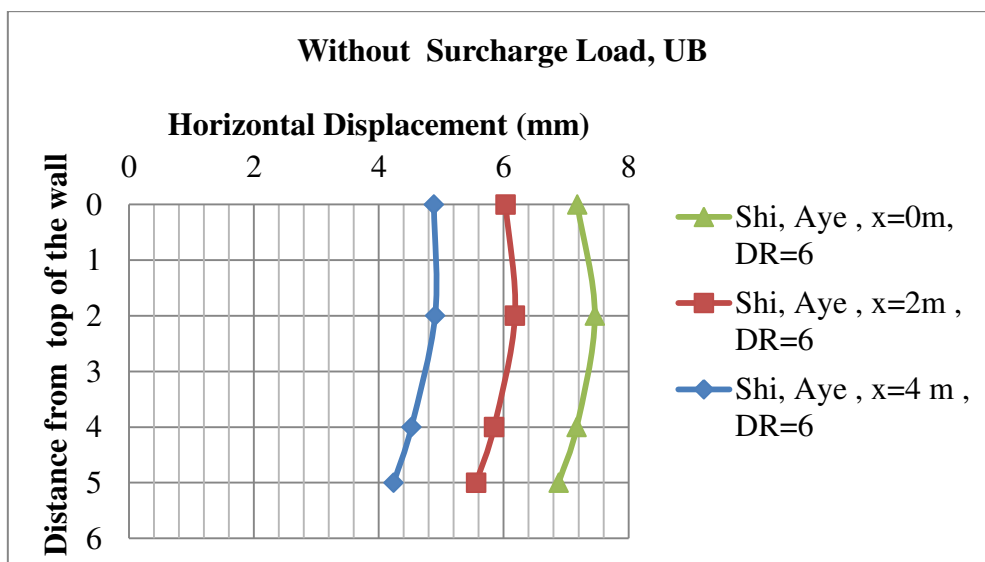

Figure 3.9. Result of Aye 2014 Method, DR=6, UB Case

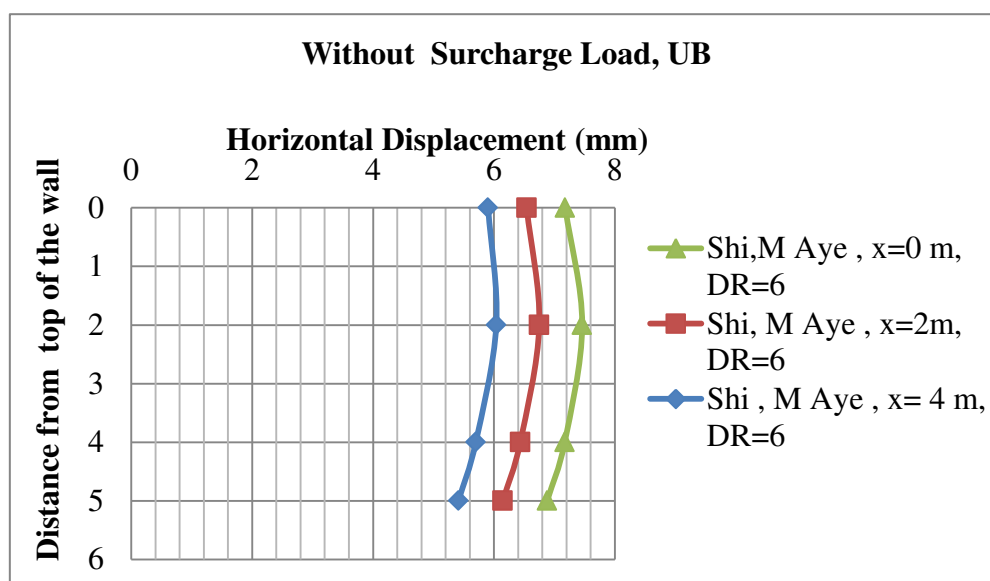

Figure 3.10. Result of Modified Aye 2017 method, DR=6, UB Case

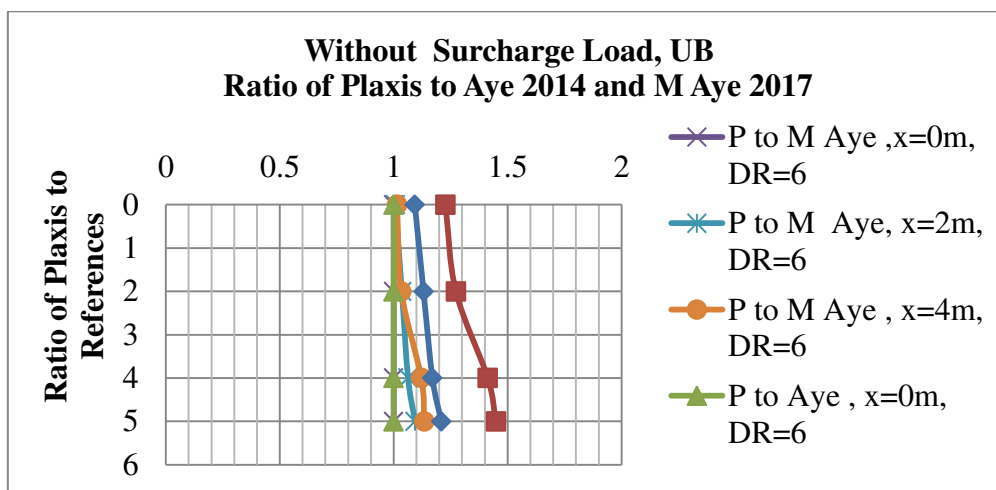

Figure 3.11. Ratio of PLAXIS to Aye 2014 and Modified Aye 2017, DR=6, UB Case

II . Middle bound case

The ratio of PLAXIS to Aye 2014 and Modified Aye 2017 are described together in Figure 3.12. Overground loss distance from the wall (Do) is $\frac{3}{4} H_w$ for Depth Ratio 6. Ratio of Plaxis to Aye 2014 (x = 0 to x = 4 m) DR = 6 is 1 to 1.37 at top of the wall, 1 to 1.386 at depth = 5 m. Ratio of Plaxis to Modified Aye 2017 (x=0 to x= 4 m) DR = 6 is 1 to 0.94 at top of the wall, 1 to 1.08 at depth = 5 m.

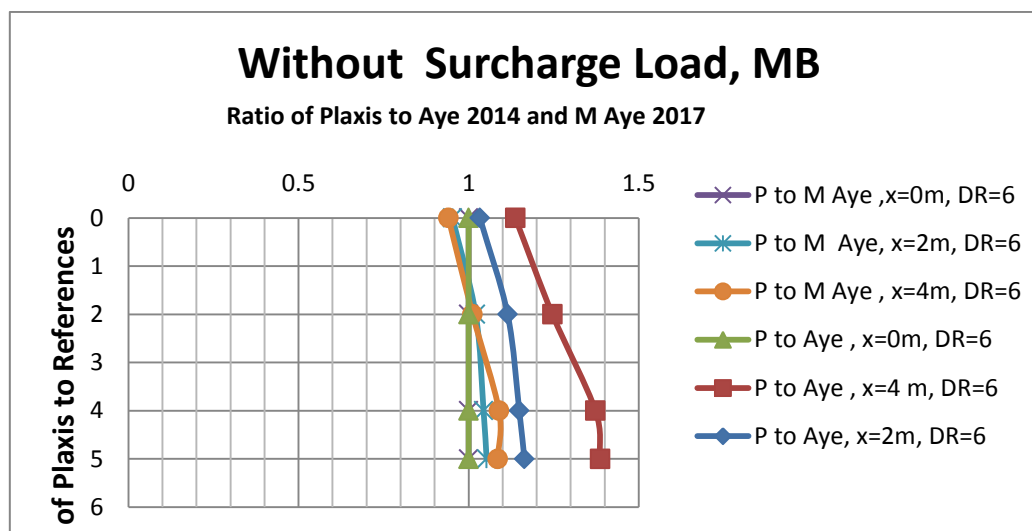

Figure 3.12. Ratio of PLAXIS to Aye 2014 and Modified Aye 2017, DR=6, MB Case

3.6.4 Prediction for Vertical Ground Movements

Prediction for vertical ground movement by soil structure interaction analysis (PLAXIS), firstly PLAXIS results (x=0 m, x=2 m, x=4 m) is obtained. Then vertical deflections are determined based on Bowles method, Aye 2014 method, Modified Aye 2017 method, Modified Bowles method.

In Upper Bound Cases, (Avg: $C_u = 105.27 \text{ kN/m}^2$) vertical displacement is very small.

In Middle Bound Cases, (Avg: $C_u = 71.77 \text{ kN/m}^2$), although depth ratio is increasing 5.2 to 6, Vertical displacement is nearly the same and small.

Figure 3.13 is represented from PLAXIS, Middle Bound Case. Figure 3.14 shows verticle ground movement by Bowles method, Aye 2014 method, Modified Aye 2017 method, Modified Bowles method.

Figure 3.15 are the comparison of prediction of vertical ground movement for the various distance from the wall and ratio of PLAXIS to references such as Bowles method, Aye 2014, Modified Aye 2017, and Modified Bowles method.

From Modified Aye Method, over grounds loss distance is $D = \frac{1}{2} H_w$ for Upper Bound Case and $D = \frac{3}{4} H_w$ for Middle Bound Case.

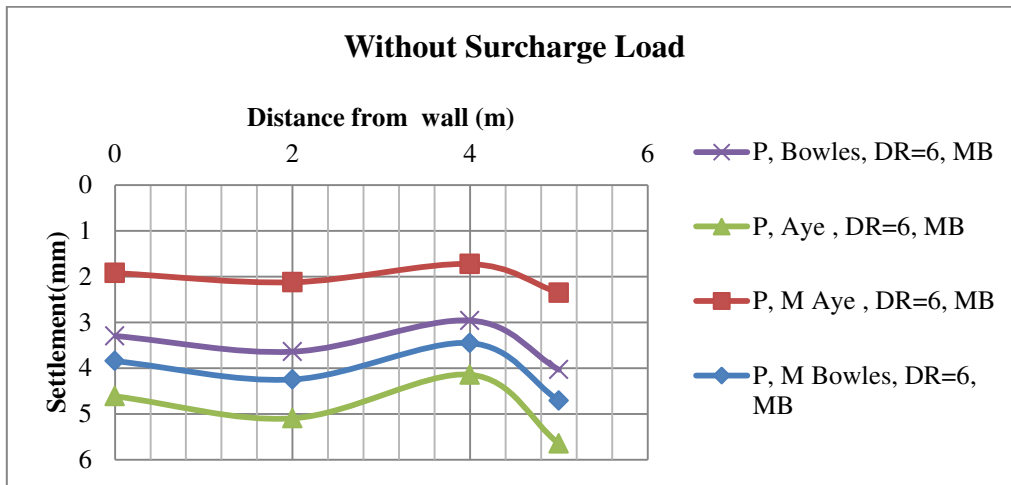

Figure 3.13. Distance from Wall Vs Settlement in DR=6, MB Case

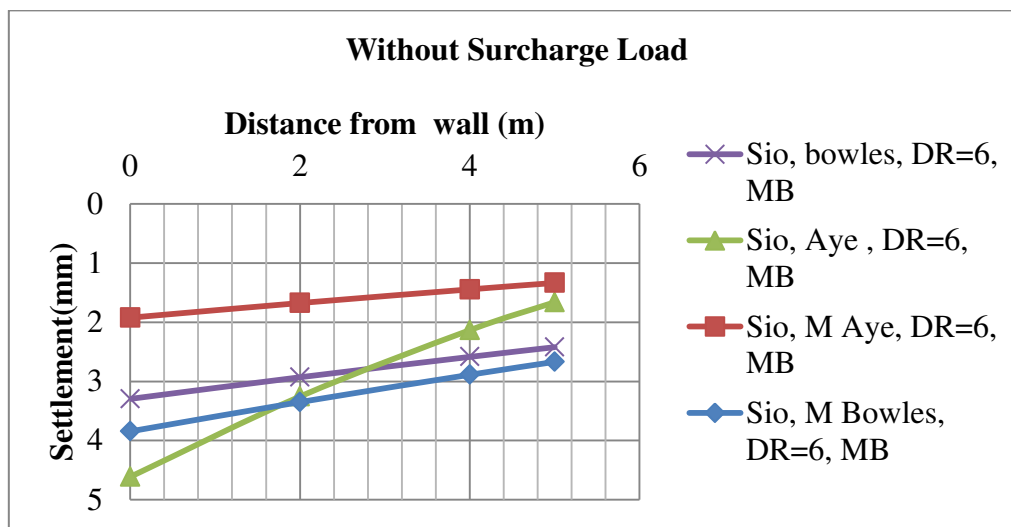

Figure 3.14. Distance from Wall Vs Settlement in DR=6, MB Case

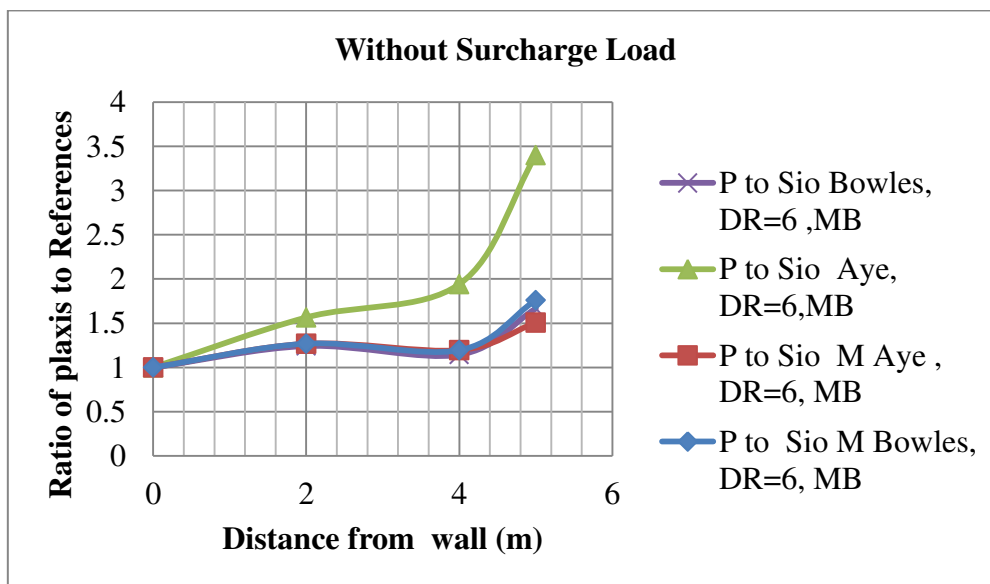

Figure 3.15. Distance from Wall Vs Ratio of PLAXIS toReferences in DR=6,MB Case.

3.7 Nomograph for Without Surcharge Load Case

Figure 3.16 describes nomograph for without surcharge load.

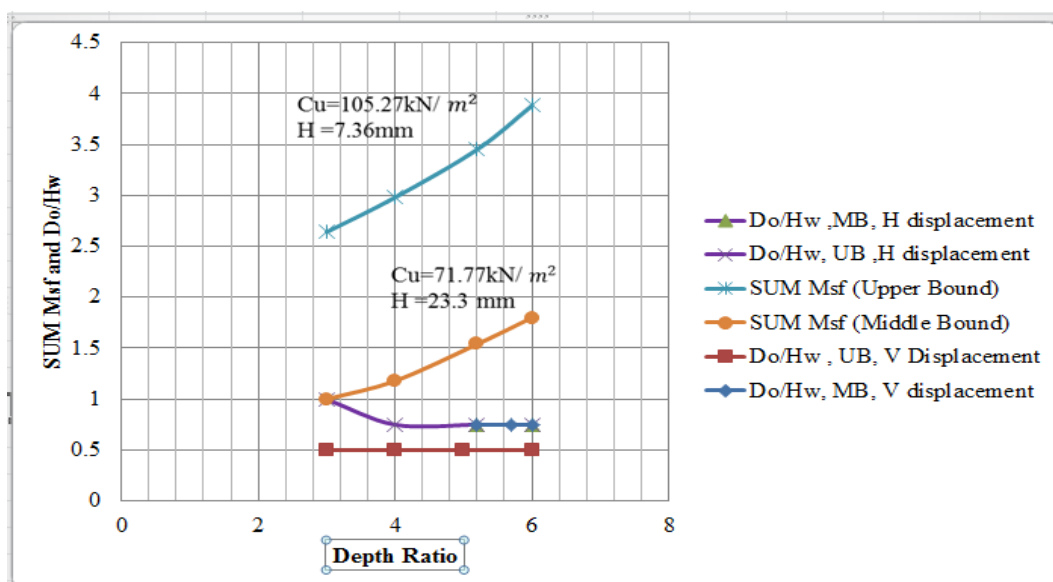

Figure 3.16. Nomograph for Without Surcharge Load

4. CONCLUSIONS AND RECOMMENDATIONS:

4.1 Without Surcharge Load Case

Lower Bound (Avg: $C_u=32.38 \text{ KN/m}^2$) is not suitable for free standing. Upper Bound Case represents average $C_u= 105.27 \text{ kN/m}^2$. Middle Bound case represents average $C_u= 71.77 \text{ kN/m}^2$.

Figure 4.1 represents nomograph of without surcharge load case. In Upper Bound Case, Depth ratio is increased 3 to 6; SUM Msf is increased as 2.64 to 3.88. Depth ratio 2 is not suitable because control panel additional step is 70 in PLAXIS.

In Middle Bound Case, Depth ratio 3 and 4 is not suitable because SUM Msf is less than 1.2. Depth ratio 5.2 and 6 have SUM Msf 1.54 and 1.7.

In Upper Bound Case (for horizontal displacement), Overground loss distance from the wall (Do) is $\frac{3}{4} H_w$ for Depth Ratio 6, 5.2 and 4. Overground loss distance from the wall (Do) is H_w for Depth Ratio 3.

In Middle Bound Case (for horizontal displacement), Overground loss distance from the wall (Do) is $\frac{3}{4} H_w$ for Depth Ratio 6 and 5.2.

For vertical displacement, Overground loss distance from the wall (Do) is $\frac{1}{2} H_w$ for Upper Bound Case and $D_o = \frac{3}{4} H_w$ for Middle Bound Case.

In Upper Bound Case, horizontal displacement is 7.36 mm and in Middle Bound Case, horizontal displacement is 23.3 mm.

4.2 Application of Nomograph

Nomographs are developed with the trend line to use in application.

Figure 4.3 represents for without surcharge load case and Figure 4.4 represents for with surcharge load case.

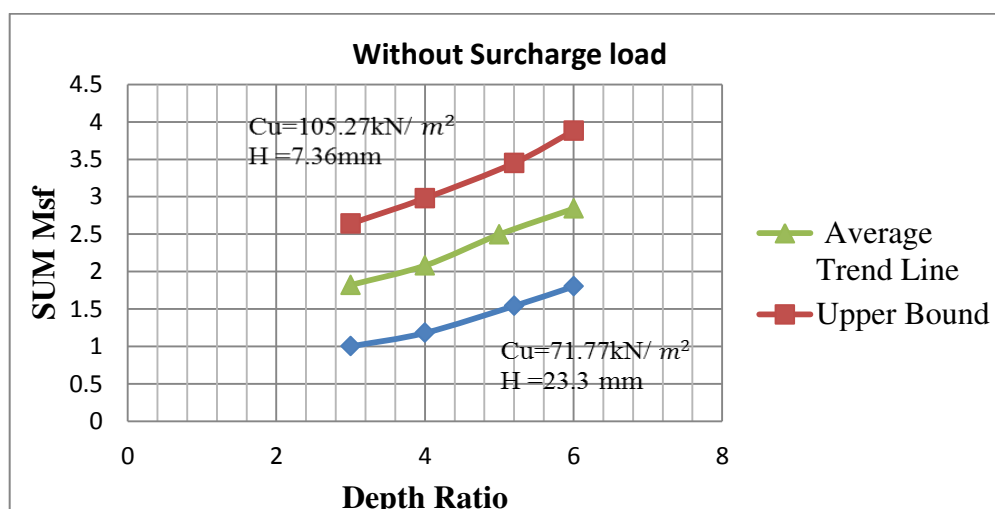

Figure 4.1 Application of Nomograph for without Surcharge Load Case

Upper Bound Case represents $C_u = 105.27 \text{ kN/m}^2$. Middle Bound case represents $C_u = 71.77 \text{ kN/m}^2$. The average trend line is $C_u = 88.5 \text{ kN/m}^2$. A user such as Civil Engineers, Geotechnical Engineers can use minimum limit of upper bound $C_u = 88.5 \text{ kN/m}^2$. Minimum SUM Msf is 1.82 for depth ratio=3 without surcharge load case. Minimum SUM Msf is 1.5 for depth ratio=3 with surcharge load case.

4.3 Application of without Surcharge Load in Mindama Street Project (Bore Hole 2)

Table 4.1. Subsoil Stratification of Mindama Street Project (Bore Hole 2)

BH No.	Layer	Depth(m)	Subsoil Type	SPT Range	Average SPT Value	Description
BH 2	I	0-1.5	Top soil	–	–	-
	II	1.5-3.00	CL	20	20	Very Stiff
	III	3.0-4.5	CL	8	8	medium
	IV	4.5-6.0	CL	7	7	Medium
BH 2	V	6.0-7.5	CL	7	7	medium
	VI	7.5-12.45	CL	13-18	15	Stiff
	VII	12.45-15.0	ML,SP-SM	14	14	Stiff/Medium
	VIII	15.0-16.5	ML	20	20	Stiff
	IX	16.5-23.0	ML	74-100	50	Hard

Table 4.2. Without Surcharge Load case of Mindama Street Project (Bore Hole 2)

SUM Msf	Depth Ratio	Average C_u	Horizontal movement(mm)	H ^a D0/Hw ^b	V ^c D0/Hw ^b
2.64	3	119	7.36	1	0.5
2.98	4	119	7.36	0.75	0.5
3.45	5.2	119	7.36	0.75	0.5
3.88	6	119	7.36	0.75	0.5

- a - Overground loss distance from the wall (Horizontal Movement)
- b – depth of the wall
- c - Overground loss distance from the wall (Vertical Movement)

4.4 Future Study

Cohesionless Soil with the drained condition is should be considered as future research.

5. ACKNOWLEDGEMENTS:

I wish to knowledge and thank all persons who kindly helped and supported me in every stage of this research. My special thanks are due to Professor Dr. Nyan Myint Kyaw, Professor, Department of Civil Engineering, Yangon Technological University for their kind permission of this study, approval of this research, and invaluable guidance during my study.

REFERENCES:

1. Asim Gaba. Ove Arup and Partners Ltd., Brain Simpson. Ove Arup and Partners Ltd. William Powrie. University of Southampton, David Beadman. Bachy Soletanche Ltd. London. 2003 Embedded Retaining Walls-Guidance for Economic Design. UK.
2. Zaw Zaw Aye. 2014. Current practices in Deep Foundations and Diaphragm Wall Construction in Thailand.
3. Nu Nu Win. 2009. Influence of Surcharge loading and Retained soil on design of Contiguous Bored Pile Wall, Preliminary Research report, Yangon Technological University.

4. Nu Nu Win. 2011. Influence of Surcharge loading and Retained soil on design of Contiguous Bored Pile Wall, ICSE , Sedona Myanmar.
5. Nu Nu Win. Influence of Surcharge loading and Retained soil on design of Contiguous Bored Pile Wall (new case study), APSEC, ACEC (Malaysia)
6. Nu Nu Win. Influence of Shear Strength Parameters and Relative Soil Stiffness on Design of Diaphragm Wall with near Surcharge Loading (ISSN – 2455-0620 Volume - 3, Issue - 8, Aug – 2017)
7. Nu Nu Win. 2017. Unit Less Ratio on Design of Diaphragm Wall with near Surcharge Loading (ISSN – 2455 0620 Volume - 3, Issue - 8, Aug – 2017)
8. Nu Nu Win. 2018. Effect of Shear Strength Parameters with Relative Soil Stiffness on Design of Diaphragm Wall, NCSE, Yangon Technological University.
9. “Code of practice for Earth Retaining Structures” BS 8002: 1994
10. Braja M. Das. California State University, Sacramento. 2011. Principles of Foundation Engineering, seventh Edition, United State of America.
11. Braja M.Das. California State University, Sacramento. 1997. Advanced Soil Mechanics, Second Edition, United State of America.
12. R.F Craig. Department of Civil Engineering, University of Dundee. 1997. Soil Mechanics, Six Edition, UK.
13. Braja M.Das. California State University, Sacramento. 1985. Principles of Geotechnical Engineering, Fourth Edition, United State of America.
14. Shamsheer Prakash, Professor of Civil Engineering, University of Missouri- Rolla, Harid. Sharma, Chief Geotechnical Engineer, Emcon Associates, San Jose, California. 1990. Pile Foundations in Engineering Practice, United State of America.
15. Joseph, E. Bowles, P.E., S.E. 1977. Foundation Analysis and Design. Fifth Edition, United State of America.